

Chapter 1:

Principles of Power Conversion

System designers need no longer be experts in power conversion. The emergence of high quality standard power modules and distributed power architectures mean that he can now concentrate on the actual system design. However, the designer still needs some knowledge of this important and complex component.

1.1 Introduction

The advent and widespread availability of reliable and efficient standard power modules has drastically changed the focus of the power system designer. In the days of centralized custom power supplies, the designer needed to understand the details of converter operation, and was often instrumental in making choices such as selection of converter topology, operating frequency and components. The need for this level of detailed knowledge about the internal workings of the converter is largely eliminated when using standard modules from reliable suppliers, and the designer can direct his time and energy to system related issues. Most of the converter topology choices will be transparent to the end user - that is, the specifications of the module and its performance in the end system will not be affected.

There are some choices, however, that will affect performance and the system designer should be familiar with these considerations. The 1999 introduction of synchronous or active rectification in power modules has drastically improved efficiency, one of the most important system considerations. Multi-phase or interleaved topologies have an effect on dynamic response, system decoupling requirements and converter form factor. The designer should have enough knowledge of the trade-offs associated with these types of design decisions to make an intelligent selection of power modules.

In this treatment of the principles of power conversion we will give only a brief summary of the various types of topologies and how they relate to each other. More focus will be given to topologies that are presently used in various Artesyn products, with the most emphasis reserved for discussion of topological choices that directly affect the specifications or system performance of the power converter.

Power Factor Correction

1.2 Basic Principles

In this section we will review why power conversion is such a ubiquitous requirement in today's electronic systems. We will define the difference between up conversion and down conversion and also distinguish between the two circuit techniques used for power conversion - linear and switchmode regulation.

The Need for Power Conversion

With the exception of the most simple battery powered devices, all electronic equipment requires some sort of power conversion. Electronic circuitry operates from DC voltage sources while power delivery to the user's system is in the form of AC power. Furthermore, the end circuitry design is optimized to operate from specific levels of DC voltage so that more than one value of DC voltage is needed in most systems. The latest ICs now require DC voltages as low as 1V, while some circuitry operates at DC voltages up to 100V. The various DC voltage levels sometimes must be sequenced or controlled so that they can be turned on and off in a desired way. For most equipment, galvanic isolation of the DC voltages from the powerline is needed to meet international safety standards. Other standards define the interface between the powerline and the power converter(s). These types of requirements define the need for AC/DC converters.

More systems now utilize a distributed power architecture (DPA) which provides an intermediate DC voltage from which the final DC circuit voltages are derived. These DC/DC converters may or may not require isolation, but retain the need for generating specific and regulated DC voltage outputs. Sophisticated battery powered equipment such as laptop computers also

require conversion, regulation and control of the DC battery voltage in order to meet the needs of the internal circuitry.

To summarize, almost all electronic equipment uses power conversion in one form or another. The power converter performs several functions, and the relative importance of these functions will sometimes determine the topology selected for a specific converter. The functions of a power converter include:

- Isolation from the Powerline
- Meet Powerline Standards
- Provide regulated DC Voltage(s)
- Power Sequencing and Control

Up vs. Down Conversion

One primary delineation between various topologies is whether the output voltage of the converter is above or below the input supply voltage. If the output voltage is lower than the input voltage it is referred to as 'down conversion'. If the output voltage is higher than the input voltage it is referred to as 'up conversion'. Up conversion is sometimes referred to in the literature as 'boost' and down conversion as 'buck'. Often the two terms can be used interchangeably, but it should be noted that 'boost' and 'buck' are also the names of much more specific DC/DC converter topologies that will be discussed later in this chapter. For that reason, we will use 'up conversion' and 'down conversion' when referring to the voltage transformation through the converter in the more general sense.

Both of these techniques find widespread use in electronic equipment, some examples of which are listed below:

Common applications of up conversion

- Power Factor Correction (PFC)
- Generation of higher voltages in battery powered equipment
- Generation of backlight voltages for LCD displays
- UPS systems

Common applications of down conversion

- Most DC/DC power modules
- Most AC/DC converters
- IC Linear regulators

Linear vs. Switchmode Conversion

There are two basic methodologies for accomplishing power conversion. The first is called 'linear regulation' because the regulation characteristic is achieved with one or more semiconductor devices (bipolar transistors or MOSFETs) operating in their linear region. The second methodology is called 'switchmode' conversion. In this case, the voltage conversion is achieved by switching one or more semiconductor devices rapidly between their 'on' or conducting state and their 'off' or non-conducting state. We will discuss the details later, but for now we can summarize the comparison between the two by stating that the linear regulator has the advantages of simplicity, low output noise and excellent regulation whereas the switchmode converters offer the powerful advantage of high efficiency.

The majority of this chapter will focus on switchmode converter topologies since they are now the prevalent choice for most electronic equipment. However, the linear regulator still has a place and it is important to understand its performance and limitations, which we will address here.

Historically, the first active voltage regulators were linear regulators, first implemented with vacuum tubes and then with power transistors. One of their advantages is simplicity. As shown in Figure 1.1, only a few components are needed for implementation, especially with the integrated circuits available today. The schematic shows a discrete pass element, but this also can be integrated into the control IC for low power applications. A negative feedback loop is used to regulate the output voltage at the desired value by means of selecting the values of the voltage divider R1 and R2. The pass transistor (or FET) is driven by the op amp to maintain V_{out} at the desired value. Variations of V_{in} will have a negligible effect on V_{out} (good line regulation) and the load regulation is also excellent, limited only by the loop gain of the op amp circuit. Assuming a clean low-noise input voltage, the output voltage will also be very clean and quiet. Low frequency AC ripple on the input will be significantly attenuated by the gain of the regulating circuit, and the linear regulator has no inherent internal noise sources.

Power Factor Correction

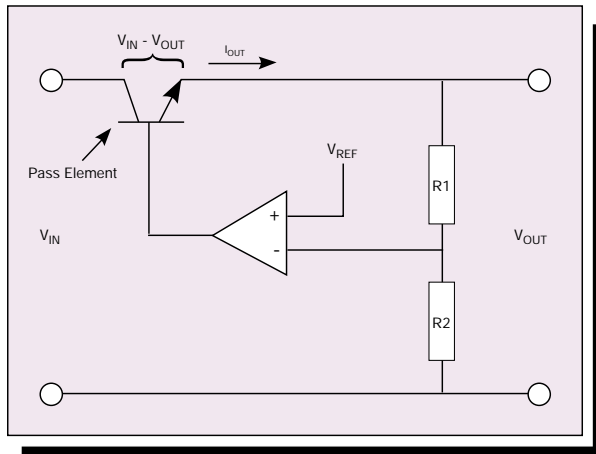

Figure 1 - Linear Regulator Topology

The key to understanding the limitations of the linear regulator is to note that the entire output current is continuously conducted by the pass element and that the DC voltage drop across the pass element will be $V_{in} - V_{out}$. Consequently, the power loss in the pass element will be given by $I_{out} \times (V_{in} - V_{out})$, and if the input voltage is significantly higher than the output voltage this power loss can be quite large and the efficiency of the regulator very low. For example, for an output voltage of 5V and an input voltage of 48V, the power loss in the pass element will be $(48V - 5V) \times I_{out}$ or $43 \times I_{out}$. The load power will be $5V \times I_{out}$ and the input power $48V \times I_{out}$. Consequently, the efficiency will be P_{out}/P_{in} or $5 \times I_{out} / 48 \times I_{out}$ or 10.4%. This would be an unacceptable efficiency for many applications.

The relationship between the input and output voltage and efficiency is shown in Figure 1.2 which assumes an output voltage of 3V. As can be seen, 60 to 70% is the highest expected efficiency when the need for a minimum voltage across the pass device and circuit operating tolerances are taken into account.

Corresponding switchmode designs can deliver efficiencies of over 85%. The efficiency characteristic of the linear regulator imposes a strong disadvantage. If there is a significant difference between the input and output voltages accompanied by a significant output current, the large power losses in the pass element will require the usage of large heatsinks which add to the size and cost of the design. Since the absolute power loss for a given ratio of V_{out}/V_{in} will be proportional to the output current, this approach will usually only be practical for low current designs.

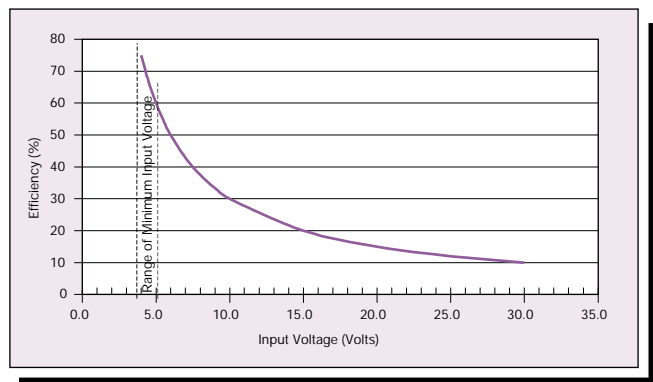

Figure 1.2 - Maximum Efficiency of 3V Linear Regulator

One obvious solution to the above problem is to set the input voltage as low as possible for a given output voltage. This will indeed drastically improve the efficiency of the linear regulator but at the expense of having to provide the preset input voltage. At other than low power levels, some type of conversion (or line-frequency transformer) would be required to do this, which adds to the complexity and cost of the overall system. Other disadvantages of the linear regulator are that it can only provide down conversion and that it has no inherent galvanic isolation between the input and output voltages. Because of the limitations described above and the availability of switchmode designs, the linear regulator is

now somewhat out of favor. It still has a place, however, mostly for low current applications where low cost is more important than efficiency. Figure 1.3 summarizes the advantages and disadvantages of the linear regulator.

Advantages	Disadvantages
Simple	Low Efficiency
Low Cost	Need for Heatsinks
Line/Load Regulation	Large Size
Low Noise	No Isolation
	Only Down Conversion

Figure 1.3 - Linear Regulator Characteristics

1.3 Switchmode Topologies

Before discussing specific switchmode topologies, we will look at some basic principles of switchmode conversion that apply to all of them. In general, switchmode converters can be either isolated or non-isolated. By isolation we imply galvanic isolation so that there is no DC path from the input of the converter to its output. In this type of converter the input and output grounds are isolated from each other, which allows for additional flexibility in system grounding configurations. The isolation also provides a safety barrier that isolates the secondary from primary voltages that are deemed to be a safety hazard to personnel. Most electronic equipment operating from the AC powerline needs at least one stage of isolated conversion to meet various agency safety requirements. On the other hand, isolation usually increases the complexity and cost of the converter and is often not required in a specific system configuration. The topology examples in this chapter will

show the most common usage of each topology - some isolated and some non-isolated. Keep in mind that it is often feasible to use the same, or similar, topology with or without isolation.

Another consideration that encompasses all topologies is the operating frequency of the converter. This is one of the most critical decisions that the converter designer makes. Fortunately the end user of the converter generally does not need to be concerned with it if the converter designer has made a wise choice. However, it is useful to be aware of the most basic considerations, which are the efficiency and size of the converter.

Converters operate by transferring energy from the input to the output. For a given power level, the energy transferred per cycle is inversely proportional to the operating frequency. Since this transferred energy is stored in capacitors or inductors during portions of the operating cycle and is transferred through a transformer in many cases, the size of these circuit elements will be smaller when a higher operating frequency is selected. So the highest possible operating frequency would appear to be advantageous.

Unfortunately, high frequency operation comes at a cost - impacts on the efficiency of the converter. The FETs, bipolar transistors and switching diodes used in power converters have two types of losses - static conduction losses and switching losses. As a first approximation, it can be assumed that the static losses will not be affected by the selection of operating frequency. The switching losses, however, are strongly influenced by the operating frequency. Each power semiconductor will exhibit an energy loss when it is turned on and again when it is turned off (or for polarity reversals in the case of diodes).

Power Factor Correction

Since the number of these energy losses per second will be proportional to the operating frequency, the overall transition power losses will increase with operating frequency and at some point the converter efficiency will degrade unacceptably. This effect is somewhat offset by using various resonant switching techniques to minimize losses, but eventually the parasitic losses associated with less than ideal components and packaging techniques will impose an upper limit on useful operating frequency.

These design trade-offs are depicted in a general way in Figure 1.4. As can be seen, there is an optimal range of operating frequency for each design. The lower operating frequency is most often limited by either the converter becoming too large or by the desire to keep the operating frequency above the audible frequency range. For these reasons, 25kHz is the lowest operating frequency that is practical. The upper limit on operating frequency is determined by efficiency, availability of specialized components and the advanced packaging and manufacturing techniques required for high frequency operation. This upper limit is now in the range of 3MHz. Most of today's converters operate somewhere in the range of 100kHz to 2MHz.

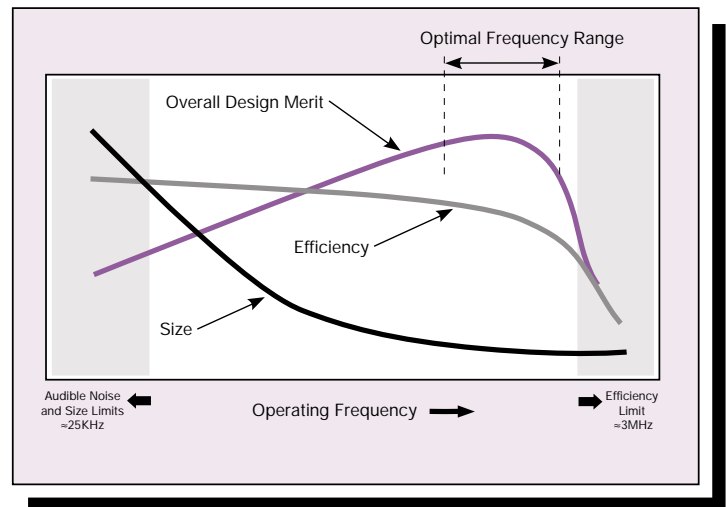

Figure 1.4 - Operating Frequency Considerations

Topology Tree

While we will look at a few specific topologies in more detail, it is useful to get an overview of how the most common topologies relate to each other. Figure 1.5 is a 'topology tree' which defines some of these relationships. It should be noted that while there are hundreds of known topologies, only the most common are shown. Switchmode converters are sub-divided into resonant variable frequency and pulse width modulated topologies. Since pulse width modulated topologies are in much wider use, they receive the most attention. Pulse width modulated topologies are further divided into direct and indirect types. Direct converters transfer energy from the input to the output during the 'on time' of the converter switch(s). Indirect converters accomplish the energy transfer during the 'off time' of the power switch(s). Some of the major benefits or areas of application are shown for each major topology along with examples of Artesyn power products that utilize some of the topologies.

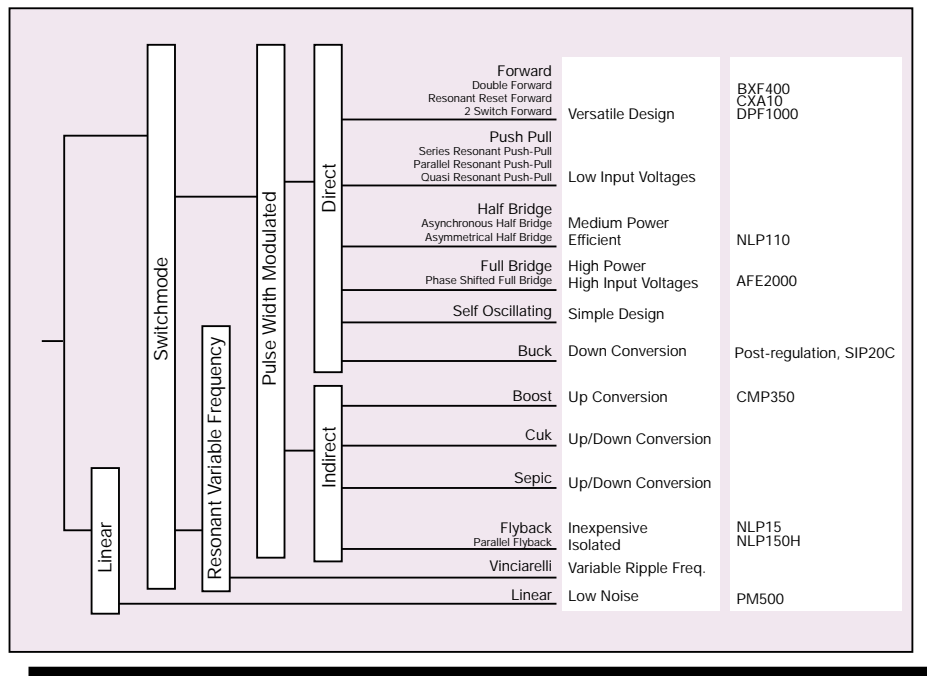

Figure 1.5 - Topology Tree

Buck

The buck topology shown in Figure 1.6 is one of the most basic. It is a non-isolated down converter operating in the direct mode. Load current is conducted directly by the single switch element during the on-time and through the output diode D1 during the off-time. Advantages of the buck are simplicity and low cost. Disadvantages include a limited power range and a DC path from input to output in the event of a shorted switch element, which can make secondary circuit protection more difficult.

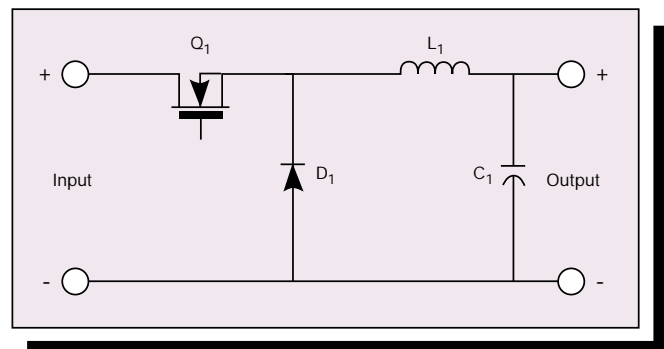

Figure 1.6 - Buck Regulator

Useful Power Level	1 to 50 Watts
Switch Voltage Stress	V_{in}
Switch Power Stress	P_{in}
Transformer Utilization	N/A
Duty Cycle	<1.0
Output Ripple Frequency	F^*
Relative Cost	Low

Power Factor Correction

Boost

The boost topology shown in Figure 1.7 is the most fundamental form of a non-isolated up converter. It is classified as an indirect converter since the energy transfer to the output occurs when the switch element is in the off state. During the on-time of the switch element, energy is accumulated in the input inductor as it is connected across the input voltage source by Q_1 . During this time, the load current is drawn from the output capacitor, which is isolated from the reverse biased diode D_1 . When Q_1 turns off, the energy stored in L_1 is released into the output through D_1 adding to the input voltage source and setting the output voltage to the desired value as a function of the converter's duty cycle.

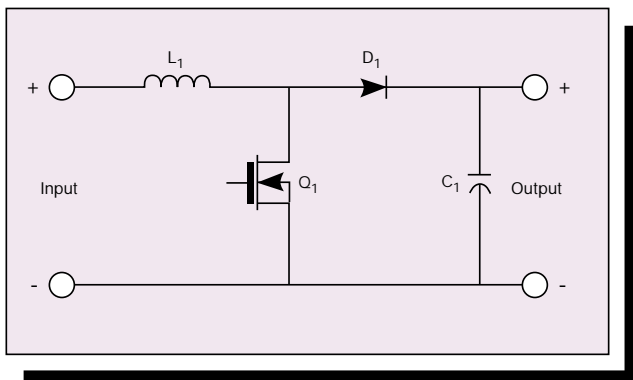

Figure 1.7 - Boost Regulator

Advantages of the boost are simplicity, low cost and the ability to achieve up conversion without a transformer. Disadvantages are a limited power range and a relatively high output ripple due to all of the off-time energy coming from the output capacitor C_1 .

Useful Power Level	1 to 50 Watts
Switch Voltage Stress	V_{out}
Switch Power Stress	P_{in}
Transformer Utilization	N/A
Duty Cycle	<1.0
Output Ripple Frequency	F
Relative Cost	Low

Flyback

The flyback converter is shown in Figure 1.8. This is a transformer-isolated topology operating in the indirect conversion mode. When the power switch Q_1 is turned on, primary current ramps up and energy is stored in the core of transformer T_1 . During this time interval, diode D_1 is reverse biased and energy to the load is supplied by the charge in capacitor C_1 . When Q_1 turns off, the negative current transition on the primary is reflected to the secondary so that D_1 becomes forward biased and current is conducted to the load and also to recharge C_1 .

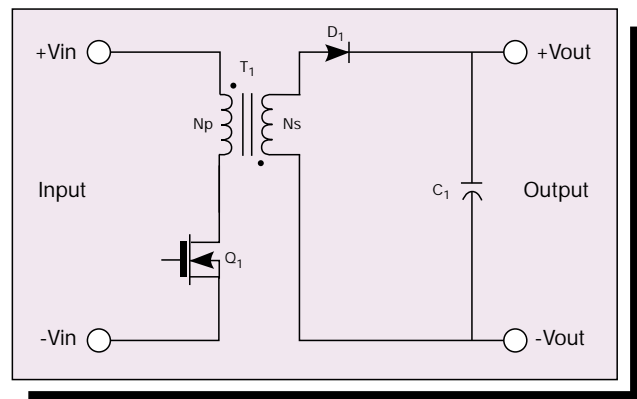

Figure 1.8 - Flyback Converter

The flyback topology is one of the most common and cost-effective means of generating moderate levels of isolated power in AC/DC converters. Additional output voltages can be generated easily by adding additional secondary windings. There are some disadvantages however. Regulation and output ripple are not as tightly controlled as in some of the other topologies to be discussed later and the stresses on the power switch are higher.

Useful power level	5 to 150 Watts
Switch voltage stress	$V_{in} + (N_p/N_s) V_{out}$
Switch power stress	P_{in}
Transformer utilization	Poor/specialized design
Duty cycle	<0.5
Output ripple frequency	F
Relative cost	Low-moderate

Forward

The forward topology is one of the most commonly used, and has several variations, the most basic of which is shown in Figure 1.9. The forward converter is essentially an isolated version of the buck converter operating in the direct mode and the basic single switch version shown can be successfully operated over a wide power range. Due to the transformer, the forward topology can be used as either an up or a down converter, although the most common application is down conversion. The power transferred to the secondary during the on-time is conducted through diode D1 to the output LC filter. During the off-time, the secondary current circulates through diode D2. The transformer is reset during the off-time by means of the auxiliary winding, N_{AUX} , and diode D3. The main advantages of the forward topology are its simplicity and flexibility.

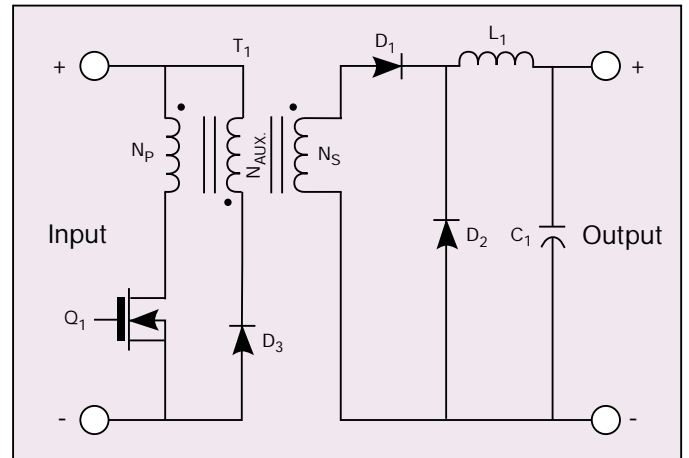

Figure 1.9 - Forward Converter

Useful Power Level	10 to 250 Watts
Switch Voltage Stress	$2 \times V_{in}$
Switch Power Stress	P_{in}
Transformer Utilization	Fair-good/no taps required
Duty Cycle	<0.5
Output Ripple Frequency	F
Relative Cost	Low

One common variation on the forward converter is the two transistor forward. This configuration adds another switch element on the other side of the transformer primary and two clamping diodes, one from each side of the primary to the opposite input voltage terminal. In exchange for this additional complexity the two transistor forward reduces the voltage stress on the switch elements.

Power Factor Correction

Resonant Reset Forward

The basic forward topology can be modified slightly, as shown in Figure 1.10, to achieve resonant reset operation. The additional capacitance C_r resonates with the magnetizing inductance of the transformer during the off-time and resets the transformer core. This increases the utilization of the transformer core and results in a much more effective magnetic design (no reset winding) along with a larger maximum duty cycle (the basic forward topology is limited to 50% duty). C_r is the combination of stray capacitance and a small discrete ceramic capacitor. The downside is that the resonant transition during the off-time increases the voltage stress on the switch element and output diodes.

Useful Power Level	10 to 40 Watts
Switch Voltage Stress	Can be $>2 \times V_{in}$
Switch Power Stress	P_{in}
Transformer Utilization	Excellent/no taps required
Duty Cycle	<0.7
Output Ripple Frequency	F
Relative Cost	Low

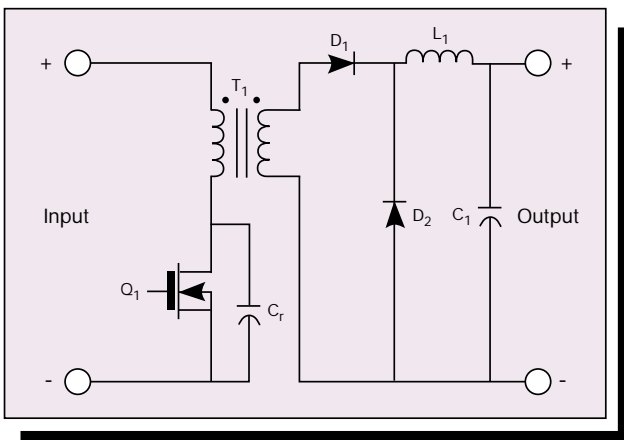

Figure 1.10 - Resonant Reset Forward Converter

Cuk

The Cuk is an indirect converter most commonly used in a non-isolated configuration as shown in Figure 1.11. It has the useful property of acting as either a down converter or an up converter as a function of the operating duty cycle (D). Its operation is more complex to understand than the other non-isolated converters presented in that energy is transferred first to C_1 from inductor L_1 during the off-time of the switching device and then into the output filter L_2 , C_2 . Besides the advantage of offering either up or down conversion, the topology is somewhat unique in that the primary and secondary are connected through a capacitor. Although this does not represent galvanic isolation and will not meet some safety requirements, it is still a useful property in that any failure mode of the power switch will not impose overvoltage conditions onto the secondary.

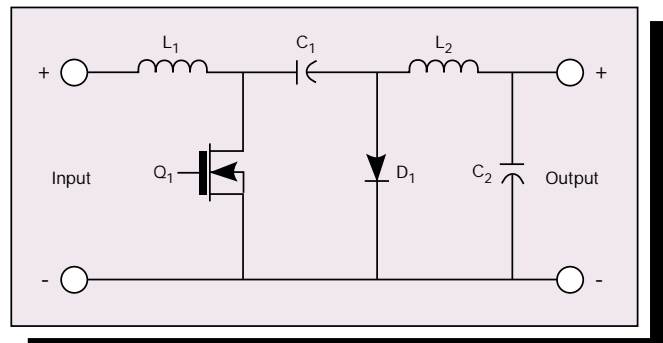

Figure 1.11 - Cuk Converter

Useful Power Level	10 to 100 Watts
Switch Voltage Stress	$V_{in}/(1-D)$ (can be high)
Switch Power Stress	P_{in}
Transformer Utilization	N/A
Duty Cycle	<1.0
Output Ripple Frequency	F
Relative Cost	Moderate

Push-Pull

The push-pull topology is shown in Figure 1.12. The power handling on the primary is shared by two switch devices each alternately conducting the primary current through half of the split primary winding. For example, when Q1 is conducting and Q2 is off, primary and secondary currents will flow in T1 such that D2 is conducting and D1 is reverse biased. Consequently, D2 will transfer power to the L1, C1 output filter. During the next cycle, load power will flow through D1. One advantage of this operation is that the output ripple frequency is twice the fundamental frequency of the primary circuit. This means that a smaller output filter is required to achieve the desired output ripple characteristic. The voltage stress on the power switches tends to limit this topology to applications with moderate input voltage levels. Consequently it is not often used for off-line converters.

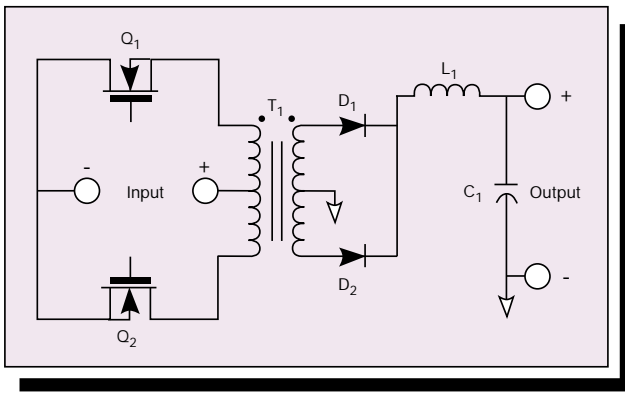

Figure 1.12 - Push-Pull Converter

Useful Power Level	15 to 150 Watts
Switch Voltage Stress	$2 \times V_{in}$
Switch Power Stress	$P_{in}/2$
Transformer Utilization	Moderate/taps required
Duty Cycle	<1.0
Output Ripple Frequency	$2 \times F$
Relative Cost	Moderate

Half Bridge

The half bridge topology, as depicted in Figure 1.13, is used in many applications due to its wide useful power range and good performance characteristics. The tapped winding full-wave secondary circuit is identical to that shown for the push-pull converter. The primary, however, is different. Capacitors C1 and C2 form a voltage divider that centers one end of the untapped primary winding at $V_{in}/2$. Power switch devices Q1 and Q2 are alternately turned on to conduct current through the primary of T1. The duty cycle can approach unity, allowing only for a minimal 'dead time' when both power switches are off. Because of the capacitive voltage divider, the non-conducting FET sees only V_{in} as a voltage stress - half the stress of the push-pull circuit. Because two power devices share the input current load and see reduced voltage stresses, the half bridge is a very popular choice for off-line converters up to several hundred watts.

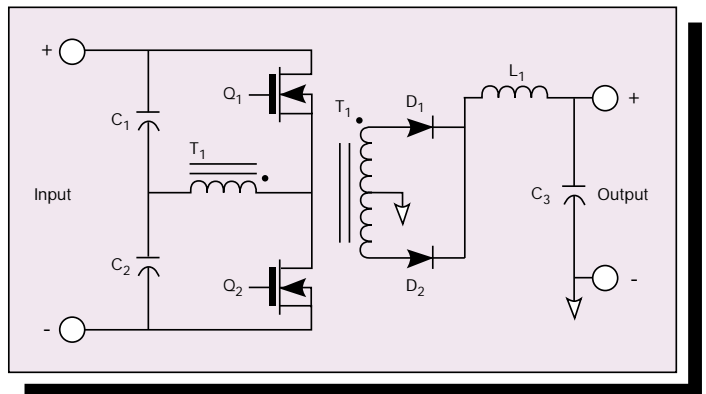

Figure 1.13 - Half Bridge Converter

Useful Power Level	50 to 400 Watts
Switch Voltage Stress	V_{in}
Switch Power Stress	$P_{in}/2$
Transformer Utilization	Good/sec. tap required
Duty Cycle	<1.0
Output Ripple Frequency	$2 \times F$
Relative Cost	Moderate

Power Factor Correction

Full Bridge

The full bridge topology, shown in Figure 1.14, is very similar to the half bridge. The only difference is that the capacitive voltage divider is replaced with two additional power switch devices. In this configuration, Q1 and Q4 conduct simultaneously to impose the entire input voltage across the transformer primary. Then, after a short dead time, Q3 and Q2 conduct to reverse the polarity of the primary current. Since the primary power is shared by two more devices than in the half bridge, with no additional voltage stresses, the full bridge converter is capable of much higher power levels. Most high power (>600W) off-line converters use some form of the full bridge. The downsides to this topology are increased complexity and cost.

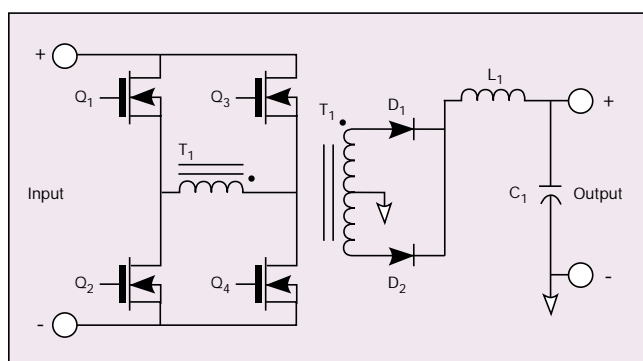

Figure 1.14 - Full Bridge Converter

Useful Power Level	200 to 2,000 Watts
Switch Voltage Stress	V_{in}
Switch Power Stress	$P_{in}/4$
Transformer Utilization	Good/sec. tap required
Duty Cycle	<1.0
Output Ripple Frequency	$2 \times F$
Relative Cost	High

Phase Shifted Full Bridge

The basic full bridge topology can be operated in a different fashion in order to derive some advantages at high power levels. Instead of varying the duty cycle of the on-times of the switching elements, each of two pairs of switching elements can be operated at a fixed 50% duty cycle. Regulation is achieved by varying the phase between the switching times of the two pairs. Figure 1.15 is a diagram showing the main elements of the phase shifted full bridge topology. Q1 and Q2 form one pair of switches, while Q3 and Q4 form the other pair. The output is configured as a current doubler rectifier. Each output inductor carries half of the load current. L_1 , on the primary side, is used to achieve zero voltage switching which helps in improving efficiency and minimizing noise generation.

There are several advantages to this approach. Note that the transformers are straight-forward in concept and do not require any secondary taps. At high load currents, the switching losses are less than with a conventional full bridge, resulting in higher efficiency for high power applications. Because of the output configuration, the ripple current in the output capacitor C_1 is low. There are also some disadvantages, however. Because of the number of magnetic parts required and the need for a sophisticated control circuit, the cost of this topology is only warranted for high power applications. Also, the efficiency advantages only apply if the converter is operated at high loads and with a limited input voltage range.

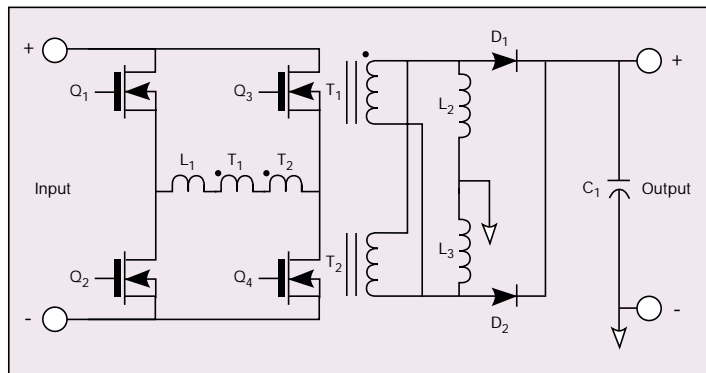

Figure 1.15 - Phase Shifted Full Bridge Converter

Pwr. Range (W)	Input Volt.	Common Topologies	Applications
1 - 15	< 15 24 / 48	Non-Isolated Buck / Boost Flyback / Forward	Laptops, PCs, Datacom Telecom / Datacom
5 - 50	24 / 48	Flyback / Forward	Telecom / Datacom / Indust.
40 - 100	24 48	Flyback / Forward / Push-Pull Flyback / Forward / Half Bridge	Telecom / Industrial Telecom / Datacom / Indust.
80 - 200	24 48 > 48	Forward / Push-Pull Forward / Half Bridge Half Bridge	Telecom / Datacom
150 - 500	All	Half Bridge/ Full Bridge	Telecom / Datacom

Figure 1.16 - Most Commonly Used DC/DC Topologies

Useful Power Level	1,000 to 5,000 Watts
Switch Voltage Stress	V_{in}
Switch Power Stress	$P_{in}/4$
Transformer Utilization	Excellent/ no taps required
Duty Cycle	<1.0
Output Ripple Frequency	$2 \times F$
Relative Cost	High

Synchronous Rectification

Efficiency is perhaps the most important criterion when selecting and applying DC/DC converters. The reasons for this will be discussed in more detail in later chapters, but for now, consider the following example. Assume an application requiring 3.0 Volts output at a power level of 30 Watts. A high quality conventional DC/DC power module could achieve an efficiency of about 84% at this voltage and power level. Using synchronous rectification could increase the efficiency to around 89%. An increase of 5% may not seem significant at first glance, but consider its ramifications, as shown in Figure 1.17.

1.4 DC/DC Topology Selection

As we have seen, there are an abundance of topologies that could be used in DC/DC converters. In practice, the number of them actually used in standard production power modules is much more limited because they sort themselves out in terms of the optimal designs for a given power level and type of application. The most commonly used topologies for DC/DC converters are summarized in Figure 1.16.

Power Factor Correction

Application (3.0V @ 30W)		
Rectification	Schottky	Synchronous
Efficiency (%)	84%	89%
Power Diss. (W)	5.7W	3.7W
Cooling	Heatsink	No Heatsink
Height (Inches)	1.0"	0.5"
Assembly	Manual HS Attach	Automated SMT

Figure 1.17 - The Value of Synchronous Rectification

The synchronous rectification reduces the power dissipated in the converter by approximately 2 Watts, which allows for the elimination of the heatsink. This, in turn, reduces the height above the circuit board by **half**, allowing for closer board to board spacing. Perhaps more importantly, it allows for completely automated SMT assembly, eliminating the need for manual assembly processes with their attendant cost and quality issues. As the output voltage level goes down, the importance of efficiency becomes more and more important. Consider that, over the next 3 years, the majority of high-performance electronics will be operating at voltage levels between 1.0 and 3.5 Volts and that voltage levels for demanding processor power applications are projected to reach as low as 0.7 Volts within the next 5 years. These types of demands will drive the need for synchronous rectification.

What is synchronous rectification? Basically, the output rectifier diodes are replaced with MOSFETs, which gives the benefit of lower conduction losses. The first generations of DC/DC converters used silicon diodes for output rectification. These diodes had a forward conduction voltage drop of about 0.7V. These were soon replaced with schottky diodes that had a forward drop of

around 0.5V. Since the power loss is this voltage drop multiplied by the conducted output current, the power losses were much improved. MOSFETs take this effect one step further by offering even lower forward conduction losses. The forward drop can be lowered dramatically by selecting MOSFETs with low drain to source on resistance and by paralleling devices for very demanding applications. The silicon area is essentially increased until the desired forward voltage drop is achieved.

They are called 'synchronous' rectifiers because, unlike conventional diodes that are self-commutating, the MOSFETs must be turned on and off by means of a signal to their gate and this signal must be synchronized to the operation of the converter. Power IC manufacturers are making this task easier for the DC/DC designer by the introduction of intelligent synchronous rectification controllers, some of which even allow for adjustable turn-on and turn-off delays to minimize deadtime and further increase efficiency.

The major disadvantage of synchronous rectification is the additional complexity and cost associated with the MOSFET devices and associated control electronics. At low output voltages, however, the resulting increase in efficiency more than offsets the cost disadvantage in many applications. The cost penalty, which is now less than \$5 per converter, should become even less as more integrated control electronics become available and volumes ramp up. Another disadvantage only applies for applications where two or more converters must be paralleled for the purpose of increasing the output power capability. In general, ORing diodes must be used in series with each converter output to prevent interaction between the MOSFETs in connected converters. If the

paralleling is done to provide redundancy, the ORing diodes would be required in any case, and the synchronous rectification would not present any particular disadvantage. Paralleling of converters will be discussed in more detail in a later chapter.

Multi-phase Topology

Another very recent development is the advent of the multi-phase converter topology, which is a technique for creating a power converter from a set of two or more identical smaller converters. These smaller converter 'cells' are connected so that the output of the resultant larger converter represents a summation of the outputs of the cells. The cells are operated at a common frequency, but with the phase shifted between them so that the conversion switching occurs at regular intervals. The basic configuration is shown in Figure 1.18. For purposes of this general discussion, the actual topology internal to each converter cell is not important.

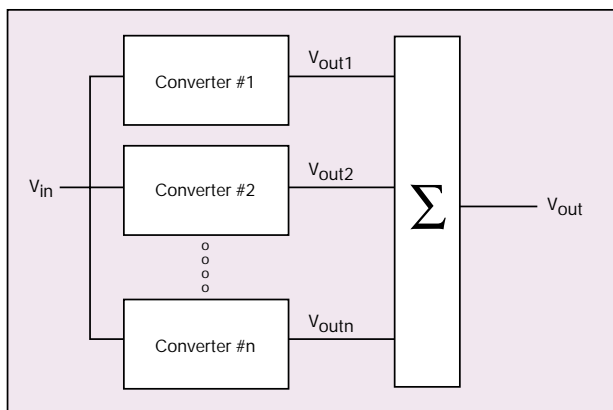

Figure 1.18 - Multi-Phase Topology

This approach provides several benefits to the end user, the most noticeable of which is the effect on the output ripple waveform. Figure 1.19 compares the ripple of a multi-phase converter for $n=2$ with the ripple of each of the cells. Note that the p-p ripple is reduced by a factor of 2 while the effective frequency is doubled. This will mean that significantly less decoupling capacitance is required in the system. The use of the multi-phase topology has essentially doubled the effective frequency while not encountering any of the component, efficiency and packaging limitations of raising the frequency of a single converter. The improvement in frequency and p-p ripple will be even more dramatic for larger values of n - the ripple frequency will be $n \times f$, where f is the operating frequency of each converter.

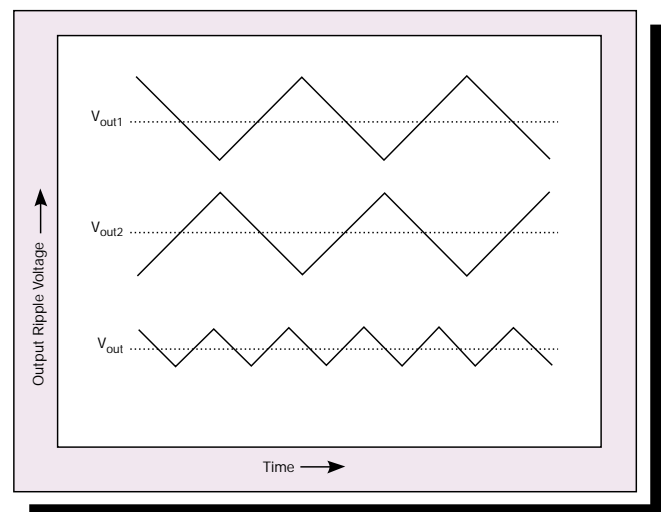

Figure 1.19 - Effect of Multi-Phase Topology on Output Ripple ($n=2$)

There are also packaging-related advantages to using a multi-phase approach. Since each cell operates at a low power level, the component sizes are much smaller than would be needed to fabricate a single converter with the same total output power. With the component height reduced, a lower profile converter can be made which

Power Factor Correction

will reduce the required board-to-board pitch. Also, since each cell is small and light, they can be mounted to the system's circuit board using automated SMT techniques, reducing assembly cost. Even a high power converter can be automatically assembled to the circuit board by this means. Since the power dissipated in the converter cells is spread out uniformly over the circuit board area, thermal hot spots are reduced relative to a single higher power converter, leading to system cooling efficiencies such as the removal of heatsinks and/or reduced air flow velocities.

The disadvantages of this approach revolve around reliability and cost. Since the total number of components in the summation of converter cells is approximately n times the number of components in a single higher power converter, high quality components and manufacturing techniques must be used to achieve the desired overall reliability. Fortunately, the component and assembly quality levels available today allow this to be achieved for many applications. The increased component count can also have an adverse impact on total hardware cost, although the savings in packaging, cooling and reduced decoupling requirements often offset this cost. To-date, the most common application for the multi-phase approach is in voltage regulator modules for high performance processor chips.

1.5 AC/DC Topology Selection

As was the case for DC/DC converters, the topologies actually in production for AC/DC converters is a small sub-set of the total number available. Since AC/DC converters operate from what is essentially the rectified AC powerline voltage, the topologies that are optimized for high voltage input will tend to be preferred. This is true for both single phase and three phase AC inputs and for all international powerline voltages. Most equipment also requires galvanic isolation of the secondary circuit voltages from the powerline, which results in the usage of isolated topologies. The most common exception is low power sealed equipment with no user access, for which non-isolated topologies are sometimes acceptable. These converters will not be covered here. The other most common exception is high voltage output non-isolated front-end power supplies that are sometimes used in high power Datacom applications as the front end for isolated DC/DC converters. These converters normally use a boost topology, which will be discussed later. Figure 1.20 shows the most commonly used topologies as a function of power level.

Power Range (W)	Isolation	Common Topologies	Common Applications
1 - 100	Yes	Flyback / Forward	Datacom, Telecom, PCs
80 - 250	Yes	Flyback / Forward / Half Bridge	Datacom, Telecom, PCs
200 - 500	Yes	Half Bridge / Full Bridge	Datacom, Telecom
500 - 1000	Yes	Full Bridge	Datacom, Telecom
50 - 2000	No	Boost	PFC, HV Front-Ends

Figure 1.20 - Most Commonly Used AC/DC Topologies

Power Factor Correction

One very common requirement for high-quality AC/DC converters is Power Factor Correction (PFC). PFC reduces the peak values of currents on the AC line and improves the harmonic content so that more power can be extracted from a given line current limitation. This need for PFC was first realized in the European market for moderate and high power AC/DC converters, but has since become a prevalent worldwide requirement for converters at all power levels.

The boost converter circuit, shown in Figure 1.21, is the most widespread technique for meeting the PFC requirement. The converter topology is identical to the basic non-isolated boost shown in Figure 1.7 but is enhanced by the addition of a control technique that allows the synthesis of an ideal rectifier characteristic. The instantaneous value of the line voltage is sensed at the rectifier output along with the current being drawn from the AC line. The controller then uses these data to vary the current as a function of voltage so that the current drawn is proportional to the line voltage over every portion of the AC line waveform, forcing a near sinusoidal current waveform on the AC powerline to maximize the power factor. In operation, the duty cycle of the boost converter will vary considerably, being higher when the AC voltage is low and very short during the peaks of the AC waveform. The output voltage of the boost converter is normally set in the range of 300 to 400 Vdc. The high operating voltages and simplicity of the circuit result in excellent efficiency, typically in the range of 95%.

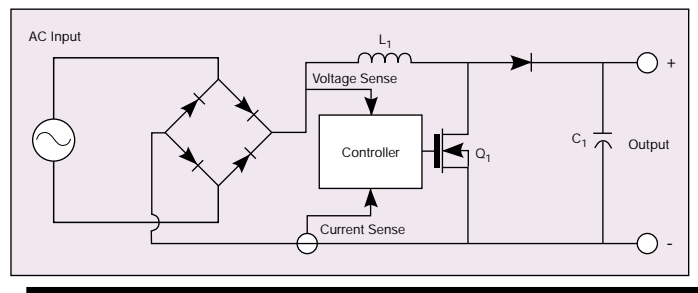

Figure 1.21 - PFC Boost Circuit

The boost converter can be used as a stand-alone front-end device to provide a source of a regulated high DC voltage for distributed power systems utilizing isolated DC/DC converters. The more common usage is as a pre-regulator internal to an AC/DC converter. This will allow the PFC standard to be met as well as provide a fixed and regulated DC voltage, independent of the AC input voltage, for the main converter to operate from. The result is a two-stage converter. Since the two converter stages are in series, there will be an impact on efficiency. Fortunately, the high efficiency of the boost converter and the ability to extract more usable power from the powerline will offset the overall efficiency consideration in many applications. Of course there is also a complexity and cost increase with the addition of the PFC stage, but the availability of PFC controller ICs is leading to increased integration and reduced cost penalties.