

Parallel & Series Operation

Contents

1. Parallel Operation
2. Series Operation

1. Parallel Operation

This is only recommended with power converters specifically designed for parallel connection. A general comment is that it is much lower cost and causes far fewer problems to use a single power converter correctly rated for the application rather than two or more in parallel. However, there are power converters which feature master slave parallel operation. These units are intended for modular expansion schemes and fault tolerant parallel redundant power systems.

Where power converters are overload protected by constant current limiting, simple parallelling of the outputs can work to an acceptable standard. Output voltages must be set the same (as precisely as possible). In a two unit system the unit with the slightly higher output voltage will reach its current limit and the voltage will drop to equal that of the other unit. This converter will then supply the remaining current demanded by the load. So regulation can never be better than the difference between the output voltage settings of the two converters, and one unit will always be operating in current limit, therefore above its rating. Where current limits are adjustable to below maximum rating simple parallelling is satisfactory if the degradation of regulation can be tolerated.

To improve load current sharing, equal series resistors can be used (See Fig. 1).

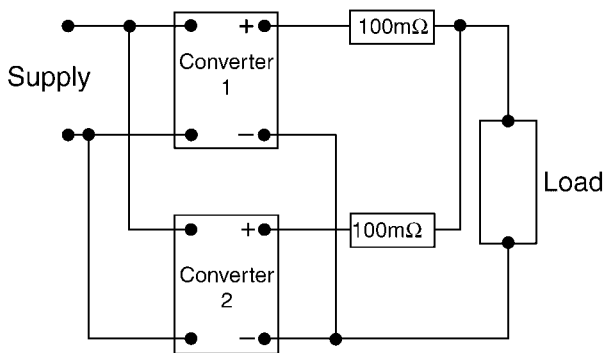
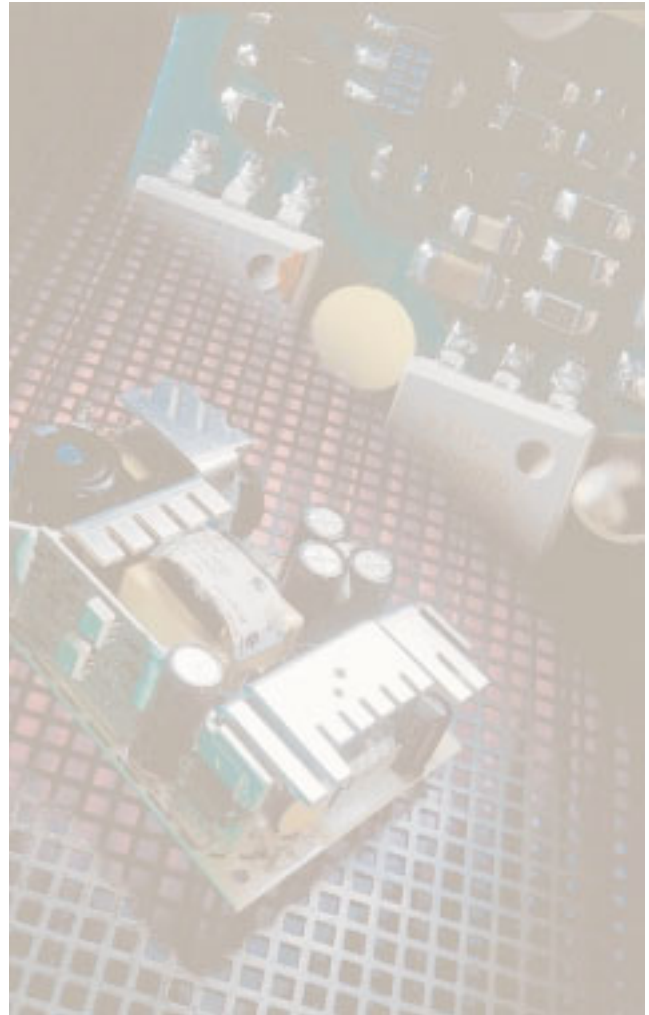

FIGURE 1

Current sharing resistors used to parallel two converters

For the best results the wiring resistance must also be exactly balanced. Small differences in the output voltage settings of the converter output still creates considerable current unbalance. In the example illustrated, the load is 5V at 2A. Converter output voltage settings are 5V but if they are unequal by 0.1V, the current out of balance from the nominal 1A is 0.5A. This requires that each unit is individually rated at 1.5A. It is clearly not a cost effective method of proving 5V 2A of stabilized power. Also the 100mΩ series resistors degrade the regulation to worse than 2%.

In critical applications where continuous operation is essential, parallel redundant power systems are often specified. The system has to keep running even when a



power unit fails. Current sharing is not such an important criterion since each power unit must be rated to supply the total load. But to enable both units to be continuously monitored for faults it is advisable that some measure of current sharing takes place. Both units are then always operating. Isolating series diodes which are continuously rated at the full load current allow either power converter to continue operation unaffected by a fault in the other. Matching the forward resistance of the diodes and balancing the wiring resistance helps with the current sharing. However, these series impedances will degrade the regulation. Some power converters, which are specifically designed for use in fault tolerant systems allow remote sense downstream of the parallelling diodes to maintain full regulation at the load. In a parallel redundant scheme one of the power converters could be replaced by a battery followed by a DC-DC converter to provide a no-break power system in the event of main supply failure

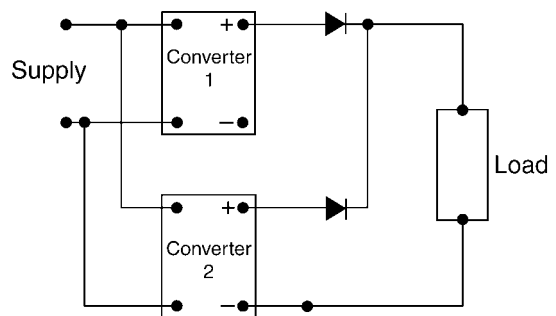

FIGURE 2

Isolating diodes used for parallel redundant connection of two converters.

Parallel & Series Operation

2. Series Operation

Most power converters can be operated in series if they have overload limit characteristics, constant current or constant power circuits. With some switching converters series operation is prohibited because one unit upsets the feedback regulation system of the other. With linear and switched mode units using foldback current limiting, lock out at switch ON can occur because of the different ramp up times of two units in series. Care must be taken not to exceed the safe working voltage at the outputs of converters in series. This may be considerably lower than the dielectric strength test voltage which is a short-term test between outputs and ground. The output ripple of converters in series is additive but this of course does not change the value of ripple expressed as a percentage of total output voltage. To protect each output from the reverse voltage applied by the other unit in the event of load short circuits, reverse biased diodes are used. It is common practice to include these protection diodes in series operation.

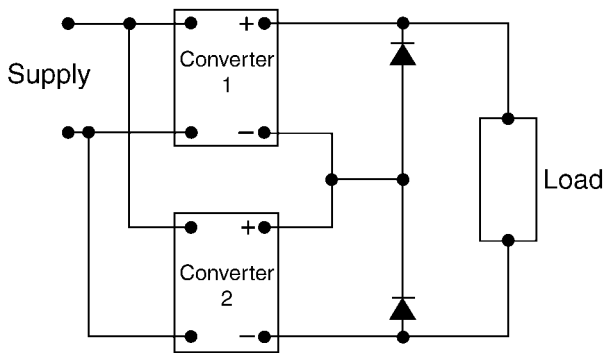

FIGURE 3
Outputs connected in series showing reverse voltage protection diodes

Cool Power has staff able to provide advice on input considerations, or any other power related issue.

Cool Power Solutions Oy
Keskustie 6
FIN-01900 Nurmijärvi
Finland

Tel : +358 (0)9 2906 1990
Fax : +358 (0)9 2906 1991
Email : info@coolpowersolutions.fi
Web : www.coolpowersolutions.fi

Disclaimer:
Cool Power does not warrant the accuracy or completeness of materials, including but not limited to the reliability of any advice, statement or other information displayed.
By the use of information within this document you acknowledge that any reliance on any such materials, advice, statement or information shall be at your own risk.